

# ISTU<sup>®</sup> Integrated Standard Transportation Unit Road Automatic Guided Vehicle concept

## ISTU<sup>®</sup> AGV - technical specification

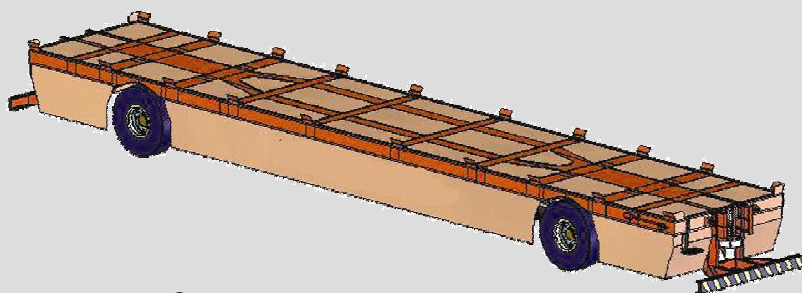

**ISTU<sup>®</sup> ROAD AGV**

- Total length (with buffers) 16940 mm
- Underframe length 15780 mm
- Vehicle width 2640 mm
- Loading platform level 1400 mm
- Weight of empty vehicle ~12,0 t
- Total weight with loading ~72,0 t
- Wheel diameter 1240 mm
- Axle base 10450 mm
- Minimum turning radius ca. 13 m
- Constant speed with loading ~10 km/h
- Maximum speed ~25 km/h
- Acceleration (loaded 30T) ~0,3 m/sek<sup>2</sup>
- Base brake: 2 braking discs installed on the traction motor shaft
- Redundant axle propulsion parking brake spring-hydraulic on each wheel
- Tire size Goodyear 14.00-20 NHS24

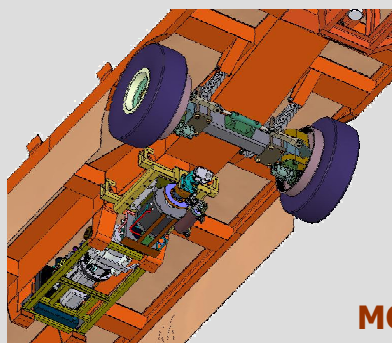

### MODULAR DRIVE SYSTEM

Power pack diesel-electric

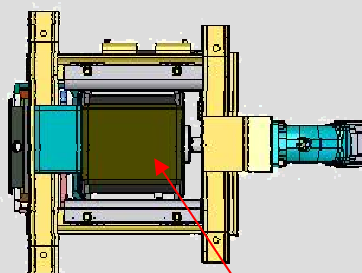
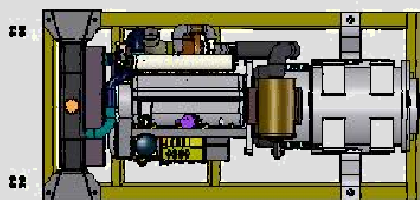

Integrated Propulsion with hydraulic single wheel torque transmission

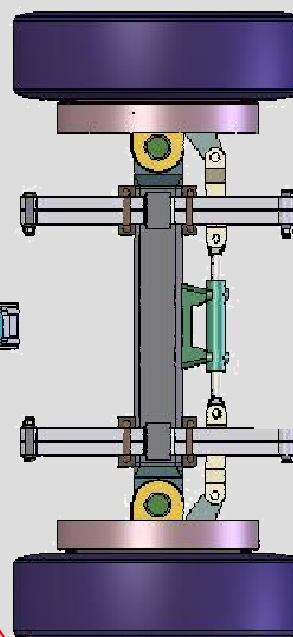

Axle with tyred wheels and hydraulic motors



### IPMOT

**Integrated Propulsion Motor Unit fully integrated PLUG and PLAY drive solution**

